



# Statutory Declaration Registration of Fittings

## (a) Design Qualification

I<sup>1</sup> Joel Feldman  
Vice President, Engineering  
*(Position eg, president, plant manager, chief eng.)*

Of Swagelok Company  
*(name of company)*

Located at Headquarters: 29500 Solon Road, Solon, Ohio 44139 USA (See Attachment A)  
*(plant address)*

do solemnly declare that the fittings listed hereunder, which are subject to the Boilers & Pressure Vessels Act:

comply with all the requirements of the ANSI/ASME codes as to their dimensions, material, identification & service for which are required:

Or

are not covered by the provisions of the ANSI/ASME codes, and are therefore constructed to comply with \_\_\_\_\_  
\_\_\_\_\_ code and standard, and are designed to the best current engineering practice, as shown by the supporting test data.

## (b) Quality control of Manufacture

I further declare the manufacture of these fittings is controlled by a quality control program which complies with the requirements of ISO 9001:2015, and has been verified by the following authority or authorized agency BSI

The fittings<sup>2</sup> covered by this declaration, for which I seek registration, are Category C. Valves

In support of the application, the following information, calculations and/or test data are attached:  
ISO 9001:2015 Certificate, Attachment A, Attachment B, Catalog Information and other Support Documents

Declared before me at \_\_\_\_\_

In the of Unable to get a notary signature or seal due to COVID-19 situation  
The \_\_\_ Day of \_\_\_\_\_ AD 20\_\_\_  
*A (commissioner for oaths)*

DocuSigned by:  
  
C87CBBFFD3F14B7  
3/2/2022 | 8:53 AM EST  
*Signature of Declarer<sup>3</sup>*

### For Official Use Only

The application is accepted for registration in Category \_\_\_\_\_ in accordance with the Boilers and Pressure Vessels Act and CSA Standard B51.

This registration must be revalidated after ten (10) years from the date of acceptance.

Registered Number CRN \_\_\_\_\_

For the Chief Inspector \_\_\_\_\_

Date \_\_\_\_\_

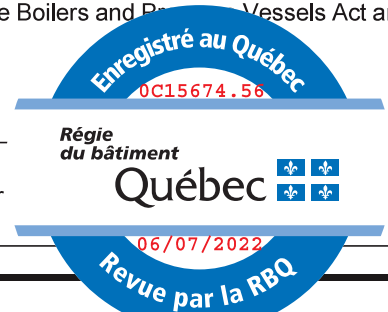

- 1 *Three completed copied of Statutory Declaration form together with three copies of Catalogs, drawings of Bureaux illustrating above fittings shall be submitted.*
- 2 *All fittings are required to be registered in the name of the Manufacturer.*
- 3 *This form shall be completed and signed by the president of highest official in the manufacturing plan where the fitting is produced.*

## Attachment B. Scope of CRN Registration for Swagelok FKB Series Medium Pressure Ball Valves (Category C)

This document represents the scope of the FKB Series Medium Pressure Ball Valves, covered by this submission for CRN approval. These products were designed and evaluated in accordance with ASME B31.3-2020 Chapter IX for unlisted components.

### Summary Table

Product Series	Main Pressure Bearing Component	Main Pressure Bearing Material (Standard)	Port Connections and Sizes	Maximum Rated Pressure (psig)		Design Code of Construction
				At 0 to 100°F	At maximum temperature	
6FKB (2-way) and (3-way)	Body	316 SS (ASTM A479)	Medium Pressure Tube Fitting 1/4", 3/8", 1/2" Female NPT 1/4", 3/8", 1/2"	15,000	15,000 at 250°F	ASME B31.3, Chapter IX (Unlisted Components)
8FKB (2-way) and (3-way)	Body	316 SS (ASTM A479)	Medium Pressure Tube Fitting 1/2", 9/16" Female NPT 1/2"	15,000	15,000 at 250°F	
12FKB (2-way)	Body	316 SS (ASTM A479)	Medium Pressure Tube Fitting 3/4"	15,000	15,000 at 250°F	
			Female NPT 3/4"	10,000	10,000 at 250°F	

### Product Illustration

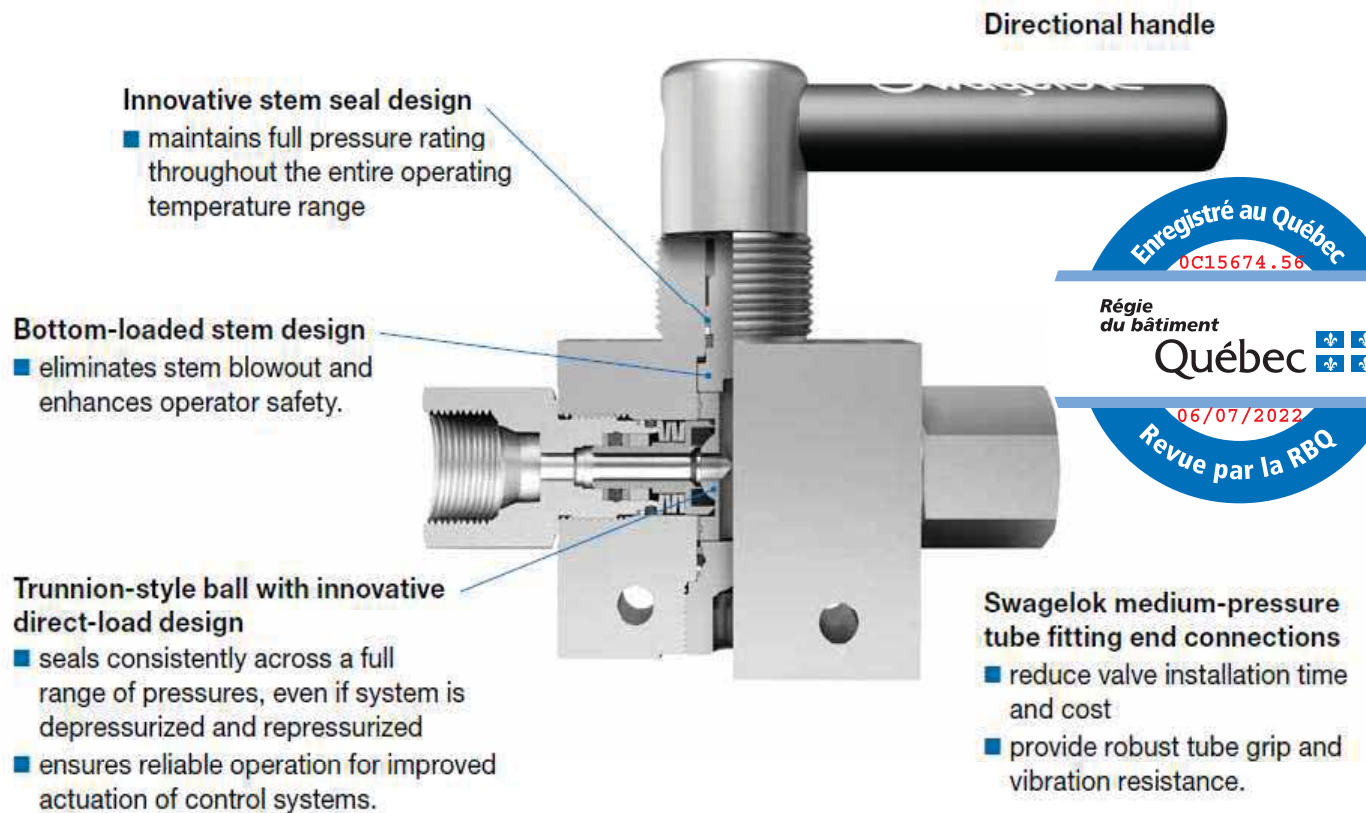

### Configurations

Valves are available in 2-way and 3-way pattern, and either manually or pneumatically actuated.

**2-Way (On-Off) Valve**

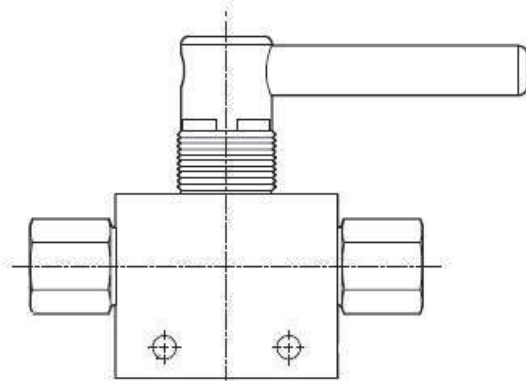

**3-Way (Switching) Valve**

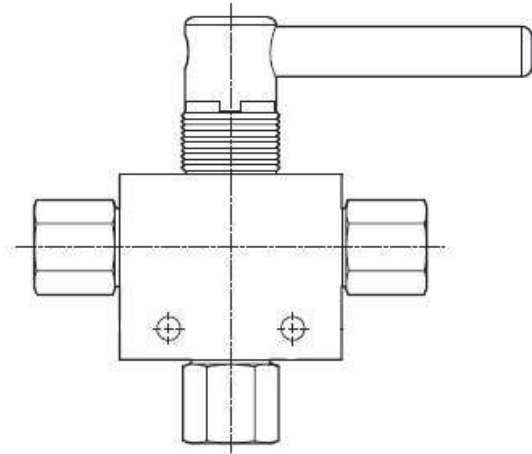

### **Typical Product Characteristics:**

Some of the product options listed below affect pressure and/or temperature ratings shown in the above Summary Table, but in all cases the ratings are less than those shown in the table. All of the following options are within the scope of this approval.

#### **O-ring Stem Seal Options**

HNBR Nitrile  
Perfluorocarbon FFKM

Additional options and non-pressure boundary alterations that do not affect pressure-temperature ratings may be made available within the scope of this registration. Examples of these would include handle options, actuator options, etc.

### **Quality System**

The Swagelok Company quality system complies with the requirements of ISO 9001:2015. The Swagelok Company maintains BSI Certificate of Registration Number FM 01729, which applies to all locations listed on the Certificate.

### **References**

The product catalog below does not represent the full scope of the registration but rather details some of the most common options.

- Medium- and High-Pressure Fittings, Tubing, Valves, and Accessories Product Catalog MS-02-472 Rev R



## Attachment A. Swagelok Manufacturing Locations

This document lists the Swagelok locations where end item or component level manufacturing activities take place.

Swagelok Company 29500 Solon Road Solon, Ohio 44139 USA	Swagelok Company (Falon 1) 348 Bishop Road Highland Heights, Ohio 44143 USA
Swagelok Company (Highland) 318 Bishop Road Highland Heights, Ohio 44143 USA	Swagelok Company (Falon 2) 358 Bishop Road Highland Heights, Ohio 44143 USA
Swagelok Company (OFC) 29495 F.A. Lennon Drive Solon, Ohio 44139 USA	Swagelok Company (HPF) 6050 Cochran Road Solon, Ohio 44139 USA
Swagelok Company (Atlantic) 26651 Curtiss Wright Parkway Willoughby Hills, Ohio 44092 USA	Swagelok Company (Snow Metal) 6060 Cochran Road Solon, Ohio 44139 USA
Swagelok Company (Micro) 26653 Curtiss Wright Parkway Willoughby Hills, Ohio 44092 USA	Swagelok Company (Alfred) 29500 Ambina Drive Solon, Ohio 44139
Swagelok Hose Services Company (SHSC) 29900 Solon Industrial Parkway Solon, Ohio 44139	Swagelok Company (Strongsville) 15400 Foltz Road Strongsville, Ohio 44119
Swagelok (China) Fluid System Technologies Ltd. Changshu Export Process Zone Changshu Economic Development Zone Changshu, Jiangshu 215513 China	Swagelok Limited Ballafletcher Road Tromode IM4 4RA Isle of Man